



## TCS3000 and 3020 Series Toroidal Conductivity Sensors



---

Resists coating, corrosion and fouling

---

Durable Noryl construction

---

Easy installation

---

Optional PEEK version available soon

---

Connects to Sensorex TCSMA, Rosemount or Foxboro Instrumentation

---

The Sensorex TCS series toroidal inductive conductivity sensors features a wide measurement range and dependability of toroidal technology. Two models are available. The TCS3000 is designed for 0-2,000 mS range and the TCS3020 is designed for optimal performance in the 0-100mS range. Resistant to corrosion, coatings and fouling common to contacting conductivity sensors, the TCS series is designed for trouble free long service life.

Noryl is the standard material of construction and has a wide solvent tolerance and temperature stability to 105 degrees C. Optional PEEK models will be available in the future. All models can be submersed by utilizing the 3/4" MNPT threads on the sensor or installed in 2" NPT tees for in-line deployment. ATC element is user specified and built into the TCS sensor.

Whether you choose the TCS 3000 or TCS 3020 as an OEM component to your toroidal controller, for use with a Sensorex TCSMA toroidal transmitter or as a replacement for Rosemount or Foxboro, you receive superior quality at a competitive price.



Liquid  
Analytical  
Solutions

Parts covered by this product data sheet include:  
TCS 3000, TCS 3020, FC95C



## OUTLINE AND DIMENSIONS

**TCS3020**

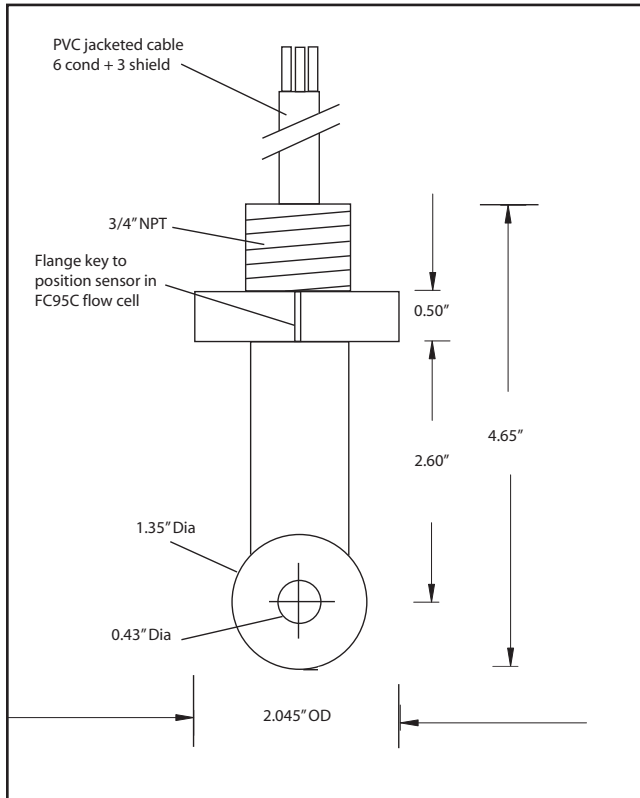

**TCS3020 MOUNTED IN FC95C FLOW CELL**

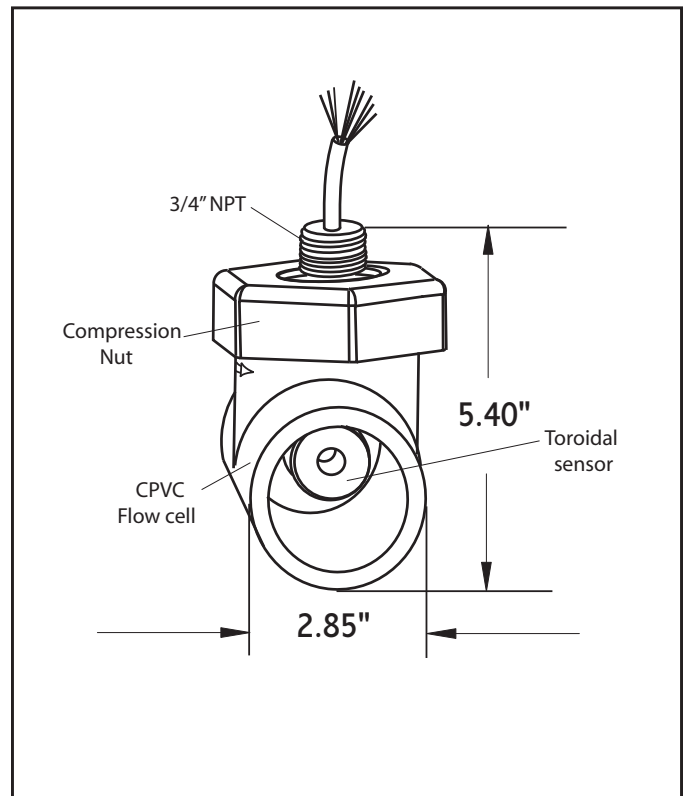

# TCS 3000 and 3020 Series Toroidal Conductivity Sensors

Designed to resist coatings and fouling for trouble free long service life. Dependable toroidal technology is now a cost effective alternative to contacting conductivity sensors.

## Specifications

Measuring Range	TCS3000 and TCS3020 - 0-2,000,000 uS/cm
Body material	Noryl - (Optional PEEK will be available in the future)
Max Temperature	105 Degrees C
Max Pressure	150 psig
Temp Comp	User specified temperature elements or -P1k for TCSMA transmitter.
Cable length	20 feet, 6 conductor plus shields
Process Connection	3/4" MNPT for submersion, 2" standard tee with A1001/A1002 adapter.

## Ordering Information

The TCS toroidal sensors are submersion ready by utilizing the 3/4" MNPT threads on the top of the sensor. In-line installations are accomplished by ordering a tee adapter or flow cell listed below.

### Sensors

TCS3000	Noryl Toroidal Sensor (Version 3) - After 05-31-2008
TCS3020	Noryl Toroidal Sensor with 20-30 windings

### Toroidal 2-Wire Transmitter

TCSMA	2-Wire Toroidal Transmitter, 4-20mA (use with TCS-3020 ONLY)
-------	--------------------------------------------------------------

### In-Line TEE Adapters

FC95C	2" Keyed slip fit flow cell (For use with Version 3 TCS3000 and TCS3020 Noryl toroidal sensors.)
-------	--------------------------------------------------------------------------------------------------

### Calibration Solutions-Quarts

TDS3000	3000ppm/3900uS
TDS15000	15000ppm/16630uS
TDS30000	30000ppm/30100uS



11751 Markon Dr.  
Garden Grove, CA 92841 USA

Tel: 714-895-4344  
Fax: 714-894-4839  
E-mail: info@sensorex.com  
www.sensorex.com