

CLD502, CLD505 and CLD510 Chlorine Dioxide Sensors

CLD502, CLD-505 & CLD510 Sensors



FC72 Flow Cell



Optional FM001 Flow Meter



Amperometric Sensor Technology

Real Time Continuous Measurement

Ranges: 0-2 or 0-10ppm

Built-In Temperature Compensation

Large Electrolyte Reservoir

Replaceable Membrane and Electrolyte

The CLD series (chlorine dioxide sensors) feature amperometric measurement technology. Designed for disinfection applications in water treatment, for use with chlorine dioxide, pools, etc., these sensors are available in two ranges for detecting ppm level of chlorine dioxide. Choose the CLD502 for 0-2ppm and CLD510 for 0-10ppm of chlorine dioxide.

Typical applications include:

- Industrial wastewater
- Cooling water
- Bottle rinsing
- Irrigation water in agriculture

Sensors output a 4-20mA signal scaled to 0-2, 0-5 or 0-10ppm. Membrane cap and fill solution are easily replaceable to maximize sensor life.

Sensors can be used in new installations with Sensorex flow cell or installed as replacement for other 4-20mA output ClO_2 sensors. (Consult Sensorex for compatibility).

An optional flow meter (FM001) is available to help provide consistent flow for added system stability.

Specifications

Measuring Range	0-2 (CLD-502), 0-5 (CLD-505) or 0-10 ppm (CLD-510) ClO_2
pH Range	4-11
Body Material	PVC
Membrane Cap Material	PVC housing, Proprietary Membrane
Temperature Range	0 - 45 Degrees C
Maximum Pressure	14.7 psig (1 Bar)
Temp Comp	Integrated
Cable Length	10 feet 2 conductors, tinned leads
Process Connection	flow cell 1/4 inch FNPT threads
Output	4-20mA
Flow Range	Min 0.2 gpm (45 l/hr), Max 0.6 gpm (135 l/hr)
Supply Voltage	12-24V DC, 250mA minimum
Cross Sensitivity	Ozone, monochloramine

Parts covered by this product data sheet include:
CLD502, CLD510, FCLA-5015 thru FCLA-5018, FC72, FM001

CLD502, CLD505 and CLD510 Chlorine Dioxide Sensors

SENSOR DIMENSIONS

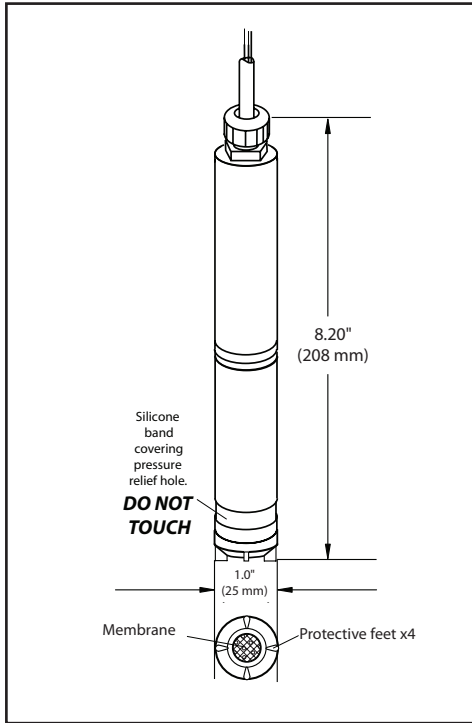

FC72 FLOW CELL DIMENSIONS

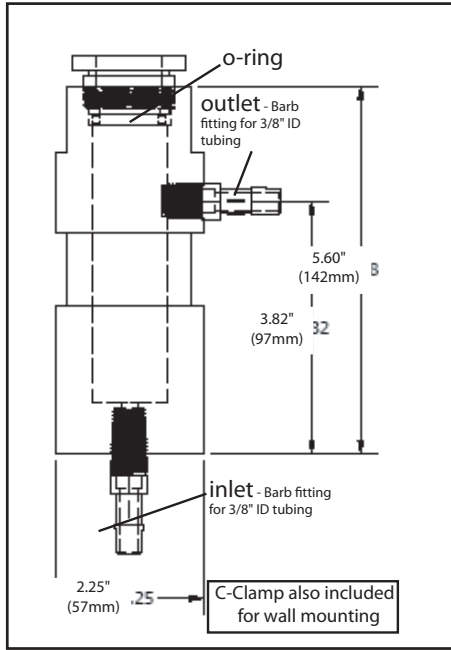

SENSOR AND FLOW CELL INSTALLATION DIMENSIONS

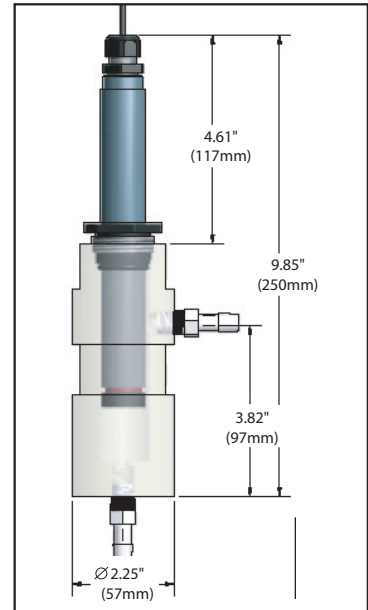

FLOW METER FM001 DIMENSIONS

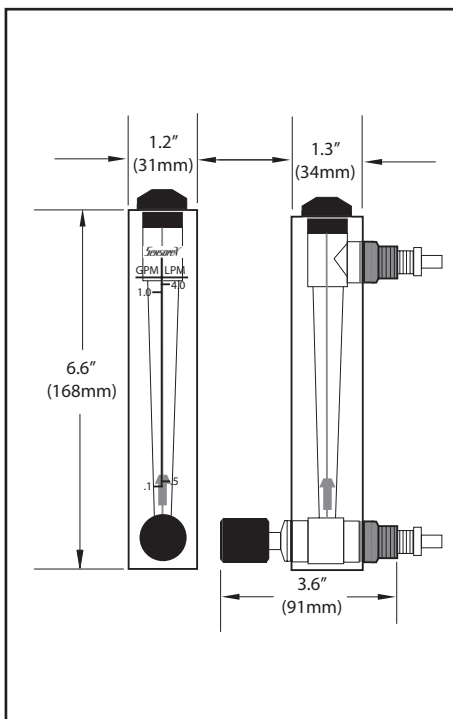

Ordering Information

Sensors

CLD502	0-2 ppm ClO ₂ 4-20mA sensor, includes 2 replacement cap, 2 each 30mL refill 3 each cathode polishing squares & 2 each pressure relief band
CLD505	0-5 ppm ClO ₂ 4-20mA sensor, includes 2 replacement cap, 2 each 30mL refill 3 each cathode polishing squares & 2 each pressure relief band
CLD510	0-10 ppm ClO ₂ 4-20mA sensor, includes 2 replacement cap, 2 each 30mL refill 3 each cathode polishing squares & 2 each pressure relief band

Accessories

FC72	Flow Cell, 1/4" FNPT inlet and outlet, includes 2 each 1/4" NPT barbed tube fittings for 3/8" ID tubing.
CLDA-5015	ClO ₂ fill solution, 30mL, 2 each
CLDA-5016	CLD sensor replacement membrane cap, 2 each, pressure relief band, 2 each
CLDA-5017	3 each cathode polishing squares
CLDA-5018	Maintenance kit for CLD5 series sensors includes: 2 replacement caps, 2 each 30mL refill, 3 each cathode polishing squares & 2 each pressure relief bands
FM001	Flow meter, 0.1-1.0 gpm (0.5-4.0 Lpm) range, 1/4" FNPT & 1/2" MNPT threads plus (2x) 3/8" tube fittings